

ADVANCEMENTS IN LINAC PERFORMANCE FOR ENHANCED STABILITY AND CONTROL: INTEGRATION OF THE LIBERA LLRF SYSTEMS INTO THE SCANDINOVA MODULATORS

K. Pepitone*, J. Gustafsson, Z. Lind, M. Lind, M. Lindholm, J. Lindström, O. Robberts, ScandiNova Systems, Typsnittgatan 15, 754 54 Uppsala, Sweden
B. Baričević, M. Cargnelutti, Instrumentation Technologies d.o.o., Solkan, Slovenia

Abstract

For years, Instrumentation Technologies and ScandiNova have developed advanced products to optimize RF performances in LINAC applications. In 2024, the companies began integrating the Libera LLRF system into ScandiNova modulators during assembly. This innovation enables the modulators to offer enhanced operational flexibility and improved performance.

This paper will focus on mechanical integration and performance results. The integrated system enables real-time monitoring of critical signals such as drive power to the RF amplifier and klystron, as well as forward and reflected klystron power. Performance metrics include amplitude stability $<0.01\%$ RMS and phase stability $<0.01^\circ$ RMS.

Experimental results are presented using a ScandiNova modulator with an S-band klystron and a standard S-band Libera LLRF. Pulse-to-pulse stability measurements demonstrate consistency between conventional electrical methods and RF-based methods, achieving stability in the 10 ppm range. Electromagnetic compatibility tests confirm that the modulators do not interfere with the LLRF system. Additionally, new tools are introduced to identify components with the greatest impact on phase stability.

INTRODUCTION

ScandiNova [1, 2] is a leading provider of high-performance pulsed power systems, specializing in solid-state modulator technology for applications in the science, industry, and medical fields. With a strong presence in particle accelerators, ScandiNova delivers reliable and efficient solutions for RF power generation, replacing traditional pulse-forming network modulators with solid-state alternatives, offering improved stability and flexibility in operation. The K-series ScandiNova modulators are widely used in research facilities, including synchrotrons, linear accelerators, and free-electron lasers.

Libera [3], developed by Instrumentation Technologies, is a renowned brand in beam diagnostics and control solutions for particle accelerators. Libera provides high-precision beam position monitoring, phase detection, and closed-loop low-level RF to optimize beam stability and performance. These systems are widely used in synchrotrons, light sources, and particle accelerators, where accurate beam diagnostics are crucial. Libera's advanced digital signal processing tech-

niques allow for real-time data acquisition and analysis, making it an essential tool for modern accelerator facilities.

ScandiNova and Instrumentation Technologies are joining forces to enhance RF power solutions by integrating the Libera Low-Level RF (LLRF) system directly into ScandiNova modulators during assembly. This integration ensures seamless communication between the modulator and the RF chain. By combining ScandiNova's solid-state modulator technology with Libera's advanced LLRF control, users gain simplified setup and greater operational flexibility.

This paper presents the first commercial closed-loop LLRF integration on a klystron modulator, covering mechanical, software, RF integration, and performance measurements.

INTEGRATION

Hardware

The RF layout, in Fig. 1, shows a configuration of RF interconnections between the Libera LLRF system and the ScandiNova modulator. In this setup, the LLRF generates the reference RF signal that drives the RF amplifier, which then gives the input power to the klystron powered by the modulator. The drive signals are continuously monitored upstream and downstream of the RF amplifier.

Forward and reflected signals are acquired via directional couplers and fed both to the ScandiNova RF digitizer system and the Libera LLRF for real-time feedback control. The reflected signal is used to fast interlock the RF amplifier, within 100 ns, in case of excessive power. Meanwhile, the Libera LLRF uses the same signals to close the feedback loop, dynamically adjusting the drive signal in real time based on the acquired RF data. This layout shows four RF inputs connected to the Libera LLRF, though additional inputs are available if required to measure or to close the LLRF feedback loop further downstream, near the linac structure.

The integration work also includes a general trigger system, which ensures correct timing synchronization between the RF amplifier, the modulator, and the LLRF system, as shown in Fig. 1.

The mechanical integration of two chassis, so-called: digital processor and analog front-end into the ScandiNova modulator, is presented in Fig. 2.

The integration includes dedicated AC power lines for both units, as well as Ethernet connections coming from an internal RJ45 switch placed in the modulator. It also

* kevin.pepitone@scandinovasystems.com

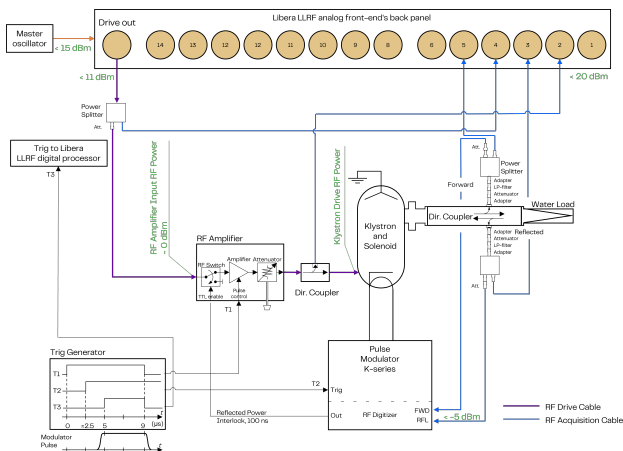

Figure 1: RF layout showing the interconnections between the Libera LLRF system and the ScandiNova modulator.



Figure 2: Picture of the Libera digital processor and analog front-end within the ScandiNova modulator.

provides the connection for the master oscillator and for the external interlock signal to the digital processor.

Software

The Libera LLRF system supports multiple control protocols, including Telnet, SSH, and EPICS-compatible protocols. It is also delivered with EPICS [4] drivers.

The ScandiNova modulator operates with a control system called ScandiCAT™, based on the industrial communication bus EtherCAT. The external interface to the control system is an operator GUI and a Modbus TCP interface for remote control.

A dedicated tab is planned to be directly accessible from the modulator's user interface, providing access to the key Libera LLRF parameters. The interface provides access to key LLRF parameters such as RF enable, interlock status and control, and setpoints for amplitude and phase, including feed-forward and loop switch settings.

Please note that the parameters displayed may vary depending on project-specific requirements, and the list is not exhaustive.

MEASUREMENTS FROM THE INTEGRATION

This section will focus on the measurements performed using the Libera LLRF installed on different ScandiNova modulators. The integration and RF interconnection, as described in the previous section and shown in Fig. 1.

To assess the electromagnetic compatibility of ScandiNova modulators with the Libera Low-Level RF system, measurements were conducted, using various RF antennas and a spectrum analyzer up to 8 GHz. These tests were aimed at identifying any potential interference that could affect LLRF performance.

The measurements were carried out on two distinct systems with the following specifications. The first system, a K100 modulator driving a 2998 MHz klystron, was evaluated both with and without RF. It operated at 106 kV and 64 A, with a 50 Hz repetition rate and an RF pulse length of 3.5 μ s. The second system, a K400 modulator operating on a load, was tested at 510 kV and 275 A.

No significant electromagnetic emissions were detected within the analyzed frequency range, confirming that ScandiNova modulators do not introduce disruptive RF noise, ensuring compatibility with sensitive LLRF systems in accelerator environments.

The system temperature was continuously monitored during modulator operation, from 23 °C to a stable value of 27 °C. This remained well within the specified operating range of the Libera digital processor and analog front-end. No signs of drift or instability were detected, confirming thermally stable behavior under nominal conditions.

EXPERIMENTAL RESULTS

A dedicated Octave script [5] was developed to analyze the acquired signals, which are shown in Fig. 3.

Phase and Amplitude Stability

Phase was measured at three locations along the RF chain (after the driver, after the amplifier, and after the klystron), using the setup shown in Fig. 1. The results presented in Fig. 3 correspond to 100 pulses at a peak power of 3.1 MW, with a pulse duration of 3.5 μ s and repetition rate of 50 Hz. The phase was measured over 1 μ s. Since the signals are time-correlated, differential phase analysis was used to isolate the contribution of each part. This approach helps isolate phase drift introduced by individual RF components. The different contributions are presented in Fig. 4.

Pulse to Pulse Stability

The pulse-to-pulse stability of a klystron system is influenced by variations in the modulator voltage, which affects the electron beam velocity and so, the phase stability of the RF output. The relationship between these parameters can be derived from relativistic mechanics.

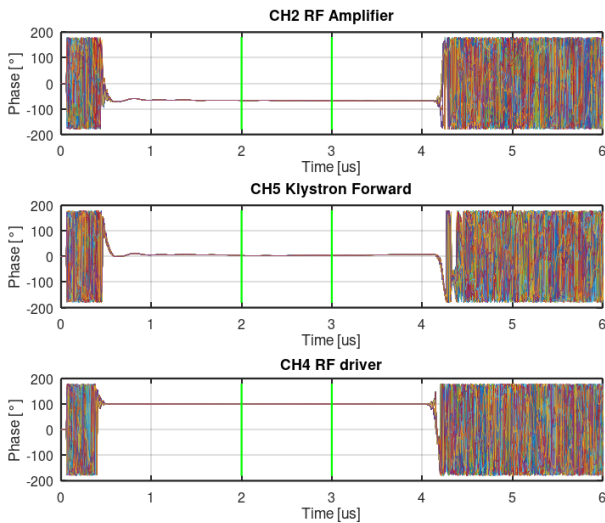

Figure 3: Phase measurement over 100 pulses at 3.1 MW, 3.5 μ s, and 50 Hz. Top: RF amplifier, middle: klystron forward power, bottom: RF driver.

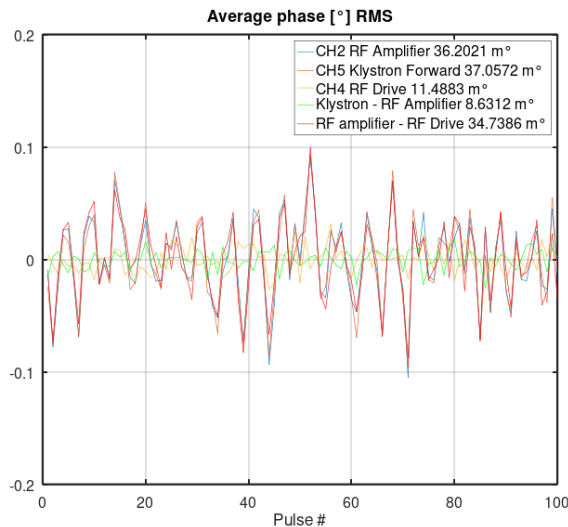

Figure 4: Pulse-to-pulse RF phase stability of each part of the chain: RF driver, RF amplifier and klystron driven by the modulator.

Knowing the modulator voltage V , the velocity of the electrons in the klystron is given by:

$$v_e = c \sqrt{1 - \left(\frac{m_e c^2}{eV + m_e c^2} \right)^2} \quad (1)$$

For a klystron having a length L and an operating frequency f , the electron transit time through the klystron is:

$$t_{\text{transit}} = \frac{L}{v_e} \quad (2)$$

While the phase stability ϕ , in degrees, is:

$$\phi = 360 f t_{\text{transit}} \quad (3)$$

Small voltage fluctuation ΔV changes the electron transit time and thus the RF phase. Knowing $\Delta\phi$, L and V , one can calculate $\frac{\Delta V}{V}$ which, when multiplied by 10^6 , gives the pulse-to-pulse stability of the modulators in ppm.

$$\Delta V = m_e c^2 \frac{c}{L} \frac{\Delta\phi}{360f} \left(\frac{(v_e/c)^2}{1 - (v_e/c)^2} \right)^{3/2} \quad (4)$$

Using relativistic relationships between modulator voltage, electron velocity, and phase delay, the stability in phase was converted to voltage fluctuation. For a klystron of length 0.45 m at 106 kV, and with a measured phase RMS of 8.6 m°, the calculated stability is 8.0 ppm (Equation 4).

To achieve a flat pulse shape, each transformer core was triggered individually, naturally canceling inductive overshoot. Additionally, CCPS charge modes were fine-tuned to concentrate charging immediately after the pulse, allowing fine control in the remaining time. This combination enabled the system to consistently reach 8 ppm voltage stability.

Long-term measurements confirmed consistent modulator behavior and phase stability. It is also important to notice that the Libera system's phase resolution is sufficient to support these measurements reliably.

In this test, both the RF amplifier and the klystron ran in saturation. Operating RF amplifier in the linear regime would additionally allow for control of the amplitude from one pulse to the other, but at the cost of slightly reduced stability.

CONCLUSION

This work demonstrates the successful integration of the Libera Low-Level RF system with ScandiNova modulators, ensuring stable and precise RF power delivery for high-power klystron applications with feedback loop. Experimental results show that pulse-to-pulse stability, measured using RF-based methods with the Libera system, reaches the 8–10 ppm range. This proves the high performance of the modulator and that signals can be acquired and processed using the high phase stability resolution of the Libera LLRF system.

Electromagnetic compatibility tests performed, on two different modulators, show no detectable interference between the modulators and the low-level RF. The temperature stability was also measured and within the operational range for the LLRF system.

It was shown that it is possible to measure the stability of each subsystem connected to the modulator and the modulator itself based on the phase stability measurements.

The integration discussed in this paper is compatible with the entire K-series modulator family and across multiple frequency bands, including L-, S-, C-, and X-band.

REFERENCES

- [1] W. Crewson, M. Lindholm, and K. Elmquist, “Green pulsed power achieved by efficient solid state pulsed power technology”, in *Proc. 18th IEEE Pulsed Power Conf. (PPC'11)*, Chicago, USA, June 2011, pp. 1471–1473. doi: 10.1109/PPC.2011.6191665
- [2] K. Elmquist, M. Lindholm, and W. Crewson, “Pulse quality”, in *Proc. 18th IEEE Pulsed Power Conf. (PPC'11)*, Chicago, USA, June 2011, pp. 1598–1601. doi: 10.1109/PPC.2011.6191689
- [3] B. B. Baricevic *et al.*, “Evaluation of the Analog and Digital Receiver Section in the Libera LLRF System”, in *Proc. PAC'09*, Vancouver, Canada, May 2009, paper WE5PFP086, pp. 2210–2212.
- [4] L. R. Dalesio *et al.*, “EPICS 7 Provides Major Enhancements to the EPICS Toolkit”, in *Proc. ICALEPCS'17*, Barcelona, Spain, Oct. 2017, pp. 22–26. doi: 10.18429/JACoW-ICALEPCS2017-MOBPL01
- [5] J. W. Eaton, D. Bateman, S. Hauberg, and R. Wehbring, *GNU Octave version 10.1.0 manual: A high-level interactive language for numerical computations*, 2025. <https://www.gnu.org/software/octave/doc/v10.1.0/>